

SPIDER 15.75 (W.H. 50 ft)



PL/TFORM[®]
MAKE YOUR
JOB
EASIER
BASKET

SPIDER 15.75



PRESTAZIONI SUPER
SUPERIOR PERFORMANCES
SUPER PERFORMANCES

Sbracci elevati in funzione del carico in navicella con una estensione massima di 27 ft 10 in in bordo navicella con 176 Lb

Big working envelope providing a maximum outreach of up to 27 ft 10 in to edge of cage at 176 Lb

Grandes extensions en fonction de la charge dans le panier avec une extension max de 27 ft 10 in bord panier avec 176 Lb

COMANDI IDRAULICI
HYDRAULIC CONTROLS
COMMANDES HYDRAULIQUES

Permettono l'utilizzo della piattaforma semplificando quelle che sono le problematiche legate ai comandi elettro-idraulici.

Simply hydraulic operating system.

Ils permettent l'emploi de l'élevateur en simplifiant les problèmes liés aux commandes électro-hydrauliques.



VERSATILITA'
VERSATILITY
VERSATILITE

Permette, a cingoli chiusi grazie agli ingombri minimi, di accedere a spazi angusti o attraverso porte, mentre a cingoli allargati di accedere in luoghi impervi con la possibilità di superare pendenze fino al 24°.

Thanks to the compact dimensions with narrow track setting, it can pass through a doorway. With extended tracks it offers excellent terrainability, offering 24° gradeability.

Permet, grace aux dimensions réduites, avec chenilles rentrées, l'accès à espaces étroits ou travers des portes, et avec chenilles élargies, l'accès à espaces étroits avec la possibilité de dépasser pentes jusqu'au 24°.



TRASPORTO
TRANSPORT
TRANSPORT

Facilità di carico su mezzi con ausilio di rampe.

Easily transportable.

Facilité de charge avec des rampes.

CARATTERISTICHE TECNICHE

TECNICAL FEATURES

CARACTERISTIQUES TECHNIQUES

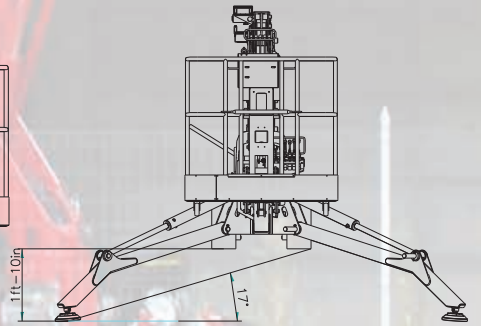
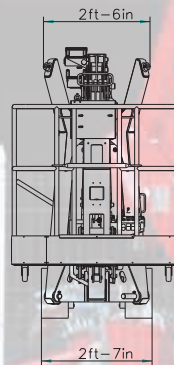
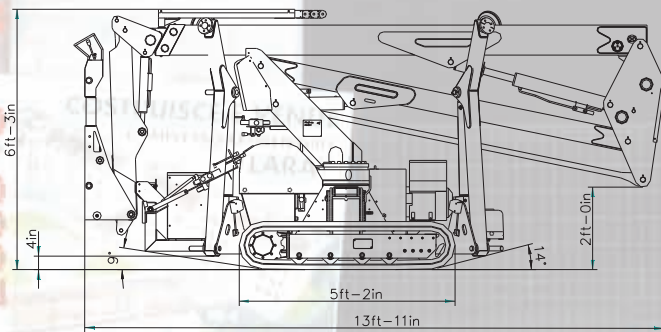
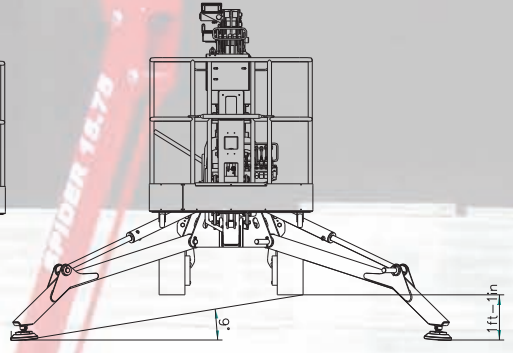
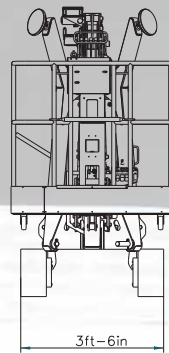
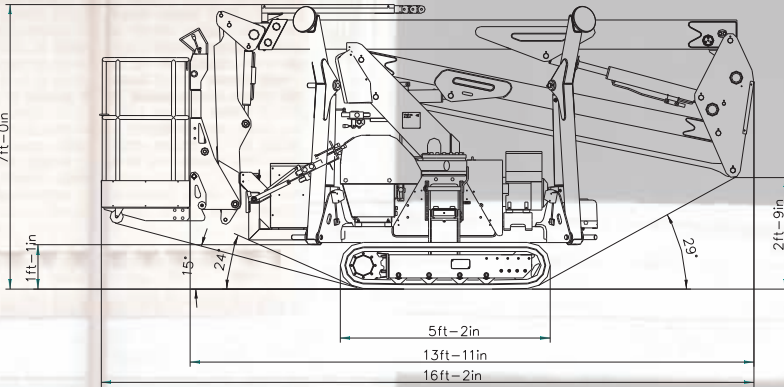
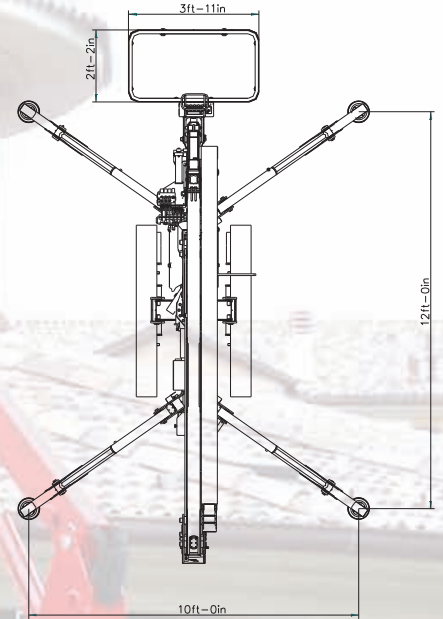
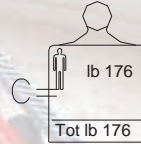
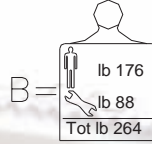
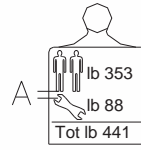
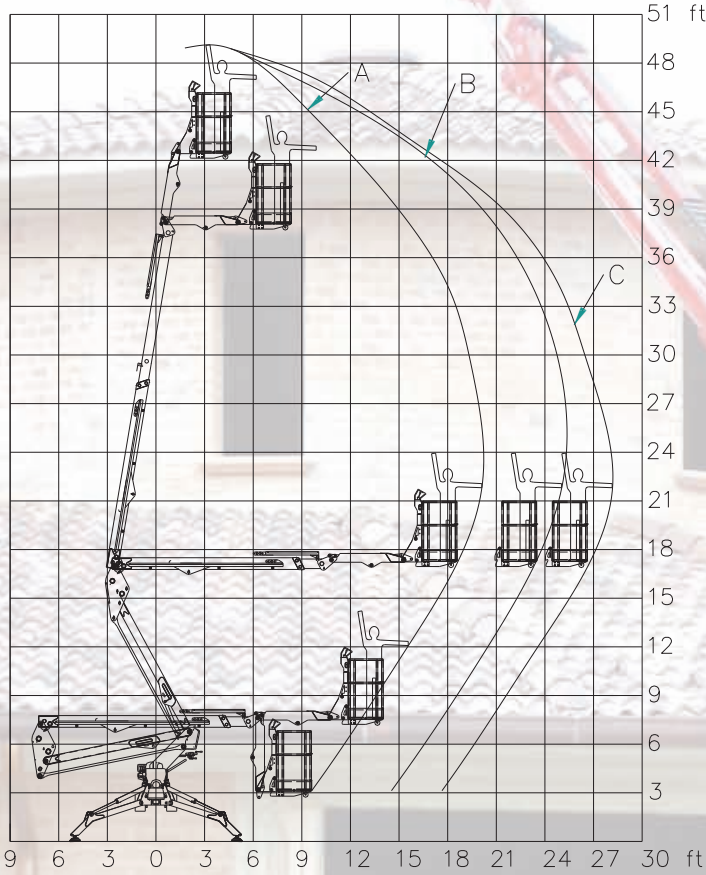

Dati dimensioni caratteristiche sono forniti a titolo indicativo e non impegnativo la PLATFORM BASKET si riserva il diritto di effettuare qualsiasi modifica senza alcun preavviso. Tutti i diritti sono di proprietà della PLATFORM BASKET ogni abuso verrà perseguito a norma di legge.

Data dimensions and features are indicative and not binding. Platform Basket reserves the right to do any changes without notice. All the rights belong to PLATFORM BASKET. Any abuse will be pursued following the rule of law.

Les données les dimensions les caractéristiques sont données a titre indicatif et n'engagé pas la maison. PLATFORM BASKET se réserve le droit d'effectuer toutes les modifications sans preavis. Tous les droits sont de propriété de PLATFORM BASKET et chaque abus sera poursuivi aux termes de la loi.

CARATTERISTICHE STANDARD
STANDARD FEATURES
 CARACTERISTIQUES STANDARD

CARATTERISTICHE TECNICHE
TECHNICAL FEATURES
 CARACTERISTIQUES TECHNIQUES

Pompa a mano d'emergenza Emergency hand pump Pompe manuelle d'urgence	Altezza di lavoro Working height Hauteur de travail	49 ft 2 in
Valvole di blocco su tutti gli attuatori Lock valves on all the actuators Valves de blocage sur les actuateur	Altezza di calpestio Working height to the basket floor Hauteur de travail au plancher	42 ft 8 in
Contaore Hour meter Computer-horaires	Sbraccio laterale Side outreach Deport laterale	27 ft 10 in/ 176 Lb 25 ft 7 in / 264 Lb 19 ft 8 in/ 441 Lb
Interblocco bracci/stabilizzatori Stabilisers/booms interblock Interblocage stabilisateurs/bras	Rotazione torretta Turret rotation Rotation tourelle	359° 359° 359°
Limitatore di momento Limiting device system Limiteur de deport	Dimensioni navicella Cage dimensions Dimensions panier	3 ft 11 in x 2 ft 2 in x 3 ft 7 in
Cingoli in gomma nero Black rubber tracks Chenille en caoutchuc noir	Lunghezza massima Length Longueur	Min 13 ft 11 in Max 16 ft 2 in
Cingoli allargabili meccanicamente Mechanical Extensible tracks Extensible Chenilles mecanique	Larghezza Width Largeur	Min. 2 ft 7 in Max 3 ft 6 in
OPTIONALS/OPTIONALS/OPTIONS Elettropompa 110/220/380 V 110/220V/380V Motor pump Electropompe 110/ 220/380V	Altezza a riposo Height in stowed position Hauteur a machine repliee	Min 6 ft 3 in Max 7 ft
Elettropompa d'emergenza 12 V Emergency motor pump 12V Electropompe d'urgence 12V	Ingombro macchina stabilizzata Overall dimensions with stabilised machine Encombrement machine stabilisee	12 ft x 10 ft
Pres a aria acqua in navicella Air water outlet in the cage Prise air eau dans le panier	Velocità traslazione Driving speed Vitesse de deplacement	0-2.0 Km./h
Pres a di corrente 110/220V in navicella 110/220V outlet in the cage Prise electrique dans le panier 110/220 V	Pendenza massima Gradeability Pente max	24°
Cingoli antitraccia No marking tracks Chenilles pas marquants	Portata massima Max capacity Max capacite	441 Lb
Colori personalizzati Personal colours Couleur personnalisee	Motore benzina Petrol engine Moteur a essence	9 Kw.
Kit anticollisione Anti-collision kit	Motore Diesel Diesel engine Diesel moteur	6.8 Kw.
	Peso totale macchina base Total weight of the machine Poids total de la machine	4080Lb

Nacelle Basket Canada
 813 Ave St-Louis
 Plessisville Québec , Canada
 (819) 362-7692